

PART NO. TG0603E0020M24

1.1 Technology Data

	Symbol		Value	Unit
Maximum allowable continuous AC voltage at 50-60Hz	V_{RMS}		~	V
Maximum allowable continuous DC voltage	V_{DC}		24	V
Trigger Voltage	V_T		300	V
Typical capacitance value measured at 1MHz	C		0.15	pF
Typical capacitance value tolerance			+0.15	pF
Maximum ESD allowable clamping Voltage*2	V_{CLAMP}		50	V
Leakage current at V_{DC*3} (At initial state)	I_{LDC}	<	0.1	uA

1.2 Reference Data

Response time	T_{rise}	<	1	ns
Operation ambient temperature			-40~ +85	°C
Storage temperature			-40~+125	°C
ESD testing	IEC61000-4-2		level 4	

1.3 Other Data

Body			ZnO	
End termination			Ag/Ni/Sn	
Packaging			Reel	
Complies with Standard			IEC61000-4-2	
Complies with RoHS Standard			Yes	
LeadFree		<	1000	ppm
Marking			None	

Notes :

- * 1 The varistor voltage was measured at 1 mA current
- * 2 The Clamping voltage was measured at 8*20 us waveform and 1A pulse current
- * 3 The Leakage current was measured at working voltage.
- * 4 The Cp was measured with zero volt bias 1Vrms at 1MHZ

2 .Size

Unit: mm	0402
L	1.00±0.12
W	0.50±0.10
T	0.50±0.10
C	0.25±0.15

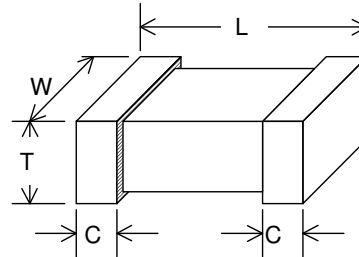

3. ESD Wave Form

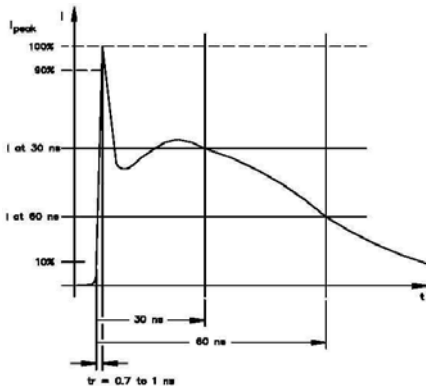

IEC61000-4-2 Standards

SEVERITY LEVEL	AIRDIRCHARGE	DIRECT DISCHARGE
1	2 KV	2 KV
2	4 KV	4 KV
3	8 KV	6 KV
4	15 KV	8 KV

IEC 61000-4-2 Compliant ESD Current Pulse Waveform

4. Environment Reliability Test

Characteristic	Test method and description			
High Temperature Storage	The specimen shall be subjected to $125 \pm 2^\circ\text{C}$ for 1000 ± 12 hours in a thermostatic bath without load and then stored at room temperature and normal humidity for 1 to 2 hours. The change of varistor voltage shall be within 10 % .			
Temperature Cycle	The temperature cycle of specified temperature shall be repeated five times and then stored at room temperature and normal humidity for one or two hours. The change of varistor voltage shall be within 10 % and mechanical damage shall be examined.	Step	Temperature	Period
		1	$-40 \pm 3^\circ\text{C}$	30Min±3
		2	Room Temperature	1 hour
		3	$125 \pm 3^\circ\text{C}$	30Min±3
4	Room Temperature	1 hour		
High Temperature Load	After being continuously applied the maximum allowable voltage at $85 \pm 2^\circ\text{C}$ for 1000 ± 2 hours, the specimen shall be stored at room temperature and normal humidity for one or two hours, the change of varistor voltage shall be within 10% .			
Damp Heat Load/ Humidity Load	The specimen should be subjected to $40 \pm 2^\circ\text{C}$, 90 to 95 % RH environment, and the maximum allowable voltage applied for 1000 hours, then stored at room temperature and normal humidity for one or two hours. The change of varistor voltage shall be within 10%			
Low Temperature Storage	The specimen should be subjected to $-40 \pm 2^\circ\text{C}$, without load for 500 hours and then stored at room temperature for one or two hours. The change of varistor voltage shall be within 10 %			

5. Soldering Recommendations

5.1 Recommended solder pad layout

(Unit : mm)

	A	B	C	D
0402	0.4~0.6	1.4~1.8	0.5~0.6	0.6~1.2
0603	0.9~1.2	2.7~3.2	0.7~1.0	0.9~1.2

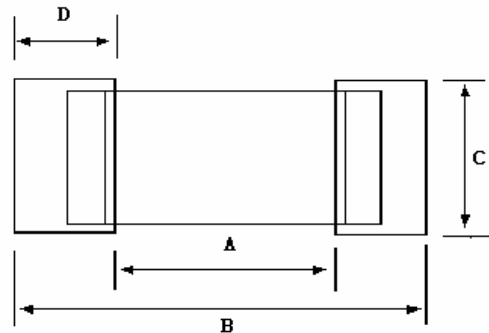

5.2 The SIR test of the solder paste shall be done (Based on JIS-Z-3284)

5.3 Steel plate and foot distance printing

Foot distance printing (mm)	Steel Plate thickness (mm)
> 0.65mm	0.18mm
0.65mm~0.5mm	0.15mm
0.50mm~0.40mm	0.12mm
>=0.40 mm	0.10mm

5.4 The IR reflow and temperature of Soldering for Pb Free

Reflow Condition		Lead-free assembly
Pre Heat	- Temperature Min ($T_{s(min)}$)	150°C
	- Temperature Max ($T_{s(max)}$)	200°C
	- Time (min to max) (t_s)	60 – 180 secs
Average ramp up rate (Liquidus Temp (T_L) to peak)		3°C/second max
$T_{s(max)}$ to T_L - Ramp-up Rate		5°C/second max
Reflow	- Temperature (T_L) (Liquidus)	217°C
	- Time (min to max) (t_s)	60 – 150 seconds
Peak Temperature (T_p)		260 +0/-5°C
Time within 5°C of actual peak Temperature (t_p)		20 – 40 seconds
Ramp-down Rate		6°C/second max
Time 25°C to peak Temperature (T_p)		8 minutes Max.

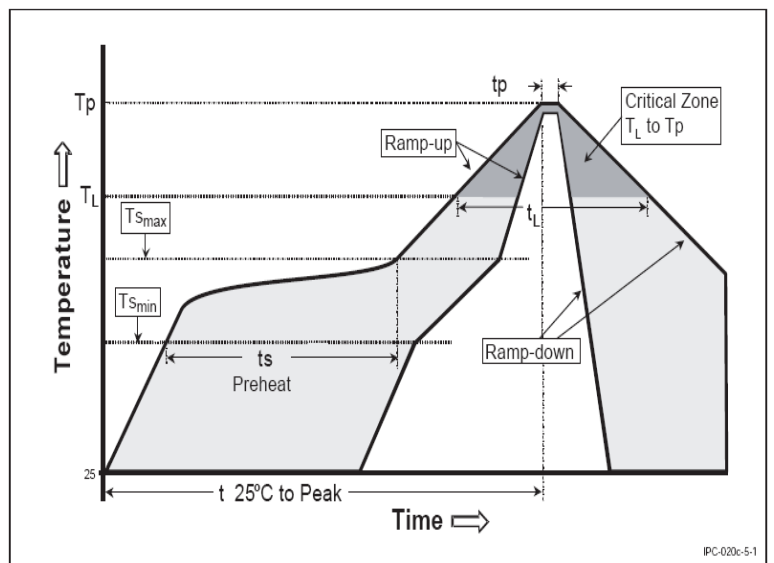

Note that this product will be easily damaged by rapid heating, rapid cooling or local heating.

Do not give heat shock over 100°C in the process of soldering.

We recommend to take preheating and gradual cooling

Soldering gun procedure

Note the follows, in case of using solder gun for replacement.

- 1) The tip temperature must be less than 280 for the period within 3 seconds by using soldering gun under 30W
- 2) The soldering gun tip shall not touch this product directly.

Soldering volume

Note that excess of soldering volume will easily get crack the body of this product.

6. Packaging Specification

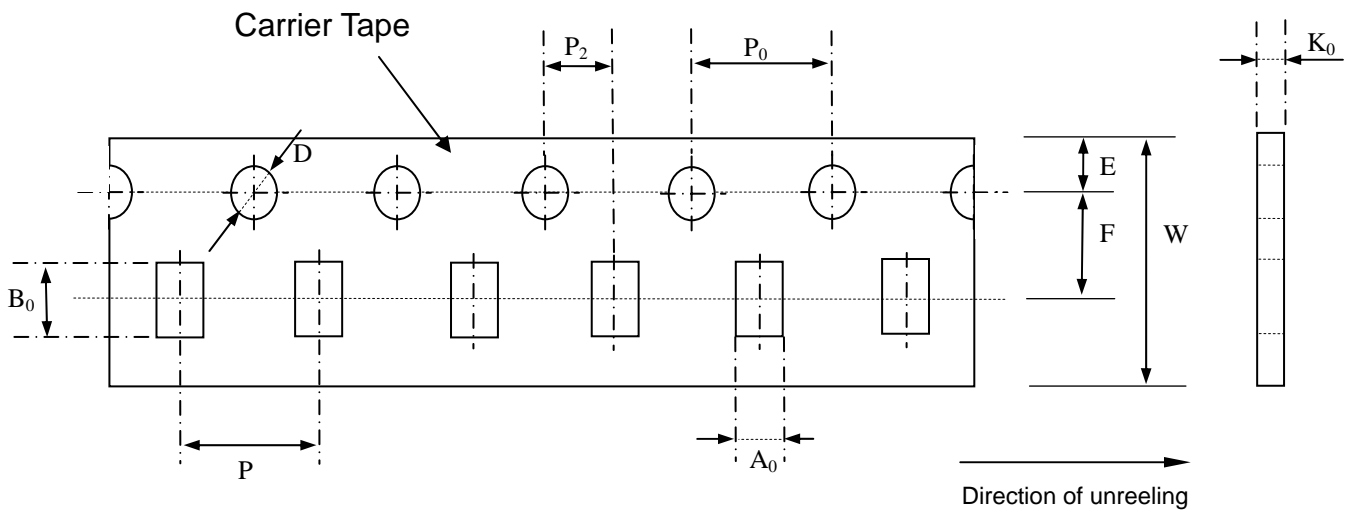

Symbol	A_0 ± 0.05	B_0 ± 0.05	K_0 ± 0.05	D $+0.10$ -0.05	P ± 0.10	P_2 ± 0.10	P_0 ± 0.10	W ± 0.10	E ± 0.10	F ± 0.05
0402	0.62	1.12	0.60	1.55	2.00	2.00	4.00	8.00	1.75	3.50
0603	1.10	1.90	0.95	1.56	4.00	2.00	4.00	8.00	1.75	3.50

7. Reel Dimension

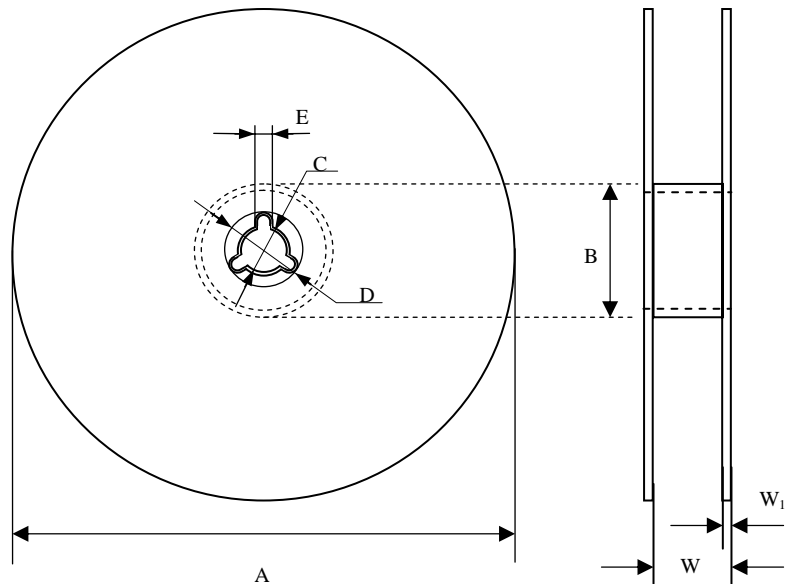

Symbol	A	B	C	D	E	W	W_1
0402	178.0 ± 1.0	60.0 ± 0.5	13.0 ± 0.2	21.0 ± 0.2	2.0 ± 0.5	9.0 ± 0.50	1.5 ± 0.15
0603	178.0 ± 1.0	60.0 ± 0.5	13.0 ± 0.2	21.0 ± 0.2	2.0 ± 0.5	9.0 ± 0.50	1.5 ± 0.15

8. Standard Packaging

Size	0402	0603
Pcs	10000	4000